

## DB24-416WHC DB24-424WHB

### Splitter Distribution Box 04 Ports 24 Cores

#### Features

- ◆ The box adopts horizontal mechanical sealing and advanced internal structure design.
- ◆ To adopt engineering PC plastic with high-strength to make the box has longer life time and excellent sealing performance.
- ◆ The box is spacious enough for winding and storing fibers.
- ◆ The patented sealing structure keep good sealing performance after re-entry and re-using.
- ◆ It is multi-functions, with different PLC splitter and adaptor panels, it could work for branch splicing, splitting and patching.

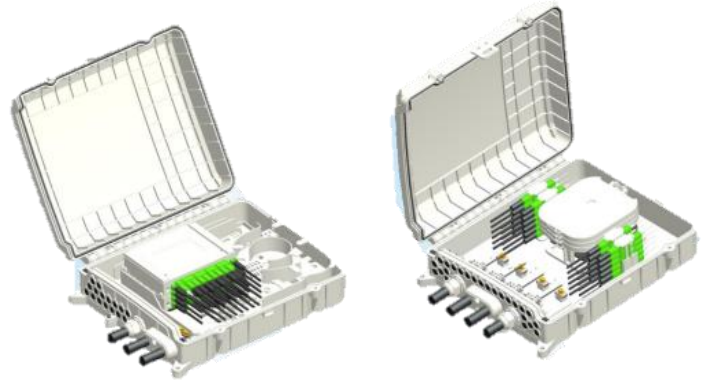

#### Application

- ◆ Suitable for bunchy fibers
- ◆ Aerial, wall-mounting, pole-mounting
- ◆ It's especially applicable to FTTH optical fiber distribution.

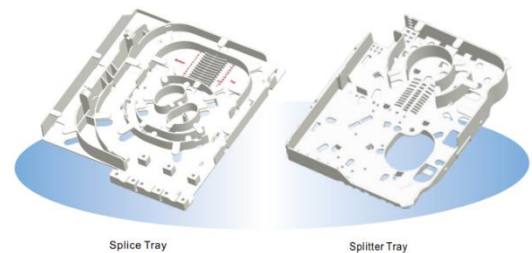

#### Dimension

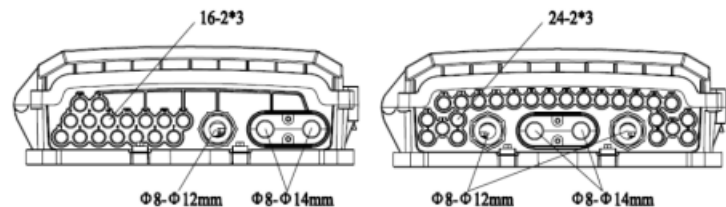
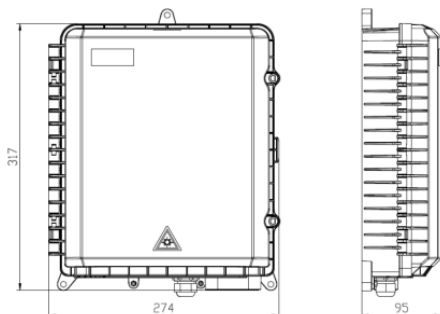

#### Specification

1	Max Capacity:	24 Cores	24 Cores
2	Cable Port:	3*round port: Φ8-Φ14mm	4*round port: Φ8-Φ14mm
3	Material:	PC	
4	Protection Grade:	IP55	
5	Splitter Type:	Cassette 1:8	Blockless 1:4/1:8
6	Splice Trays	1pcs (24f per tray)	1pcs (24f per tray)
7	Dimension(L*W*H):	274mm*317mm*95mm	
8	NO. Adapter	None	24 PCS
9	Inlets/Outlets	4/16	4/24
10	Operation temperature:	-40~+65 °C	

